

## DEWRANCE

### Features & Benefits

These valves are designed to bypass high pressure feedwater around a group of heaters in the event of high water level in the shell caused by a defective tube, weld or drain system. The time available to give protection to a turbine in modern feed systems is short but these valves can operate in approximately 5 seconds in a 300mm bore pipe system with the minimum of hydraulic shock. Protection is achieved in the system by installing fast closing tee and changeover valves in the pipework around a heater or group of heaters. These valves are equally applicable in new or established stations. The motive power employed is the feedwater pressure and the system is designed to 'fail safe' in that the heaters will be by-passed if either electric or pneumatic supplies fail.

As an alternative to the medium operated valves, a spring loaded bypass valve can be supplied. This is the simplest form of bypass which relieves at a set pressure and is fail safe.

The Dewrance design has the advantages of a pressure seal bonnet and external spring adjustment whilst the valve is still under pressure.

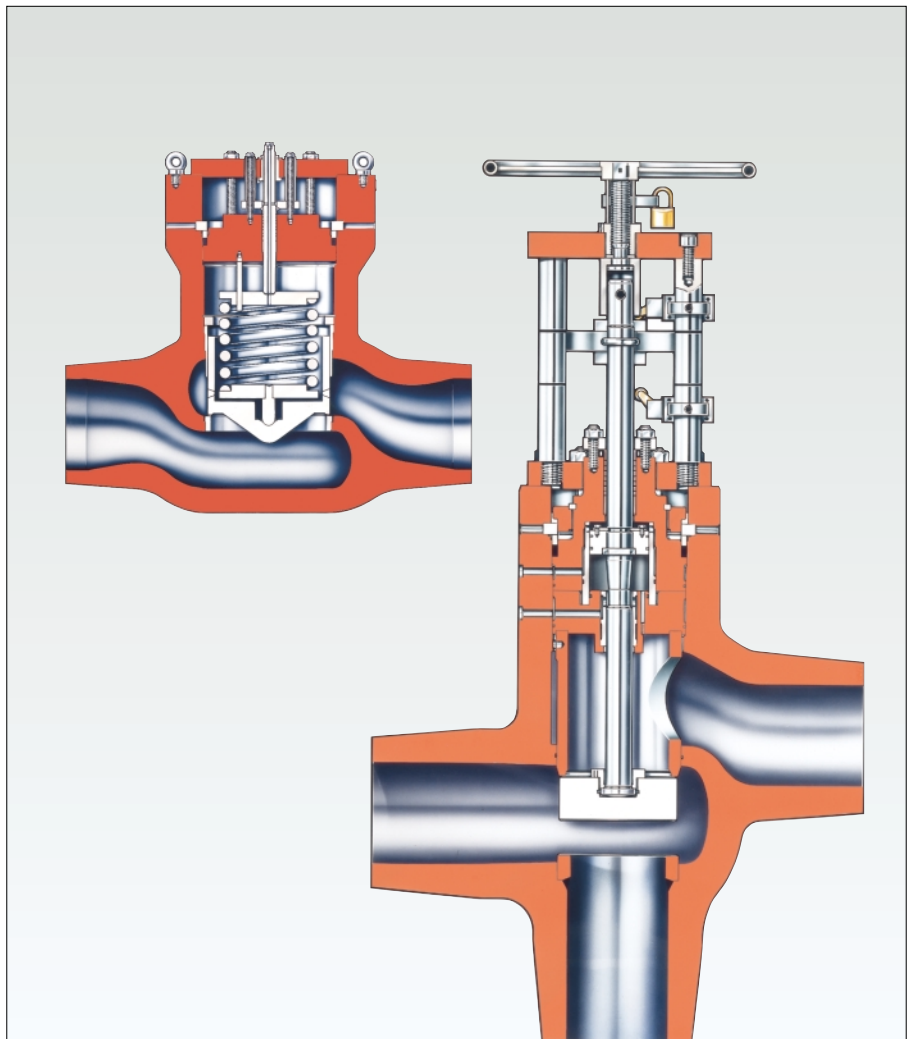

### Technical data

Sizes	: 6" – 20"
ASME	: B16.34 – 1996
Pressure Class	: 1690, 1715 int.

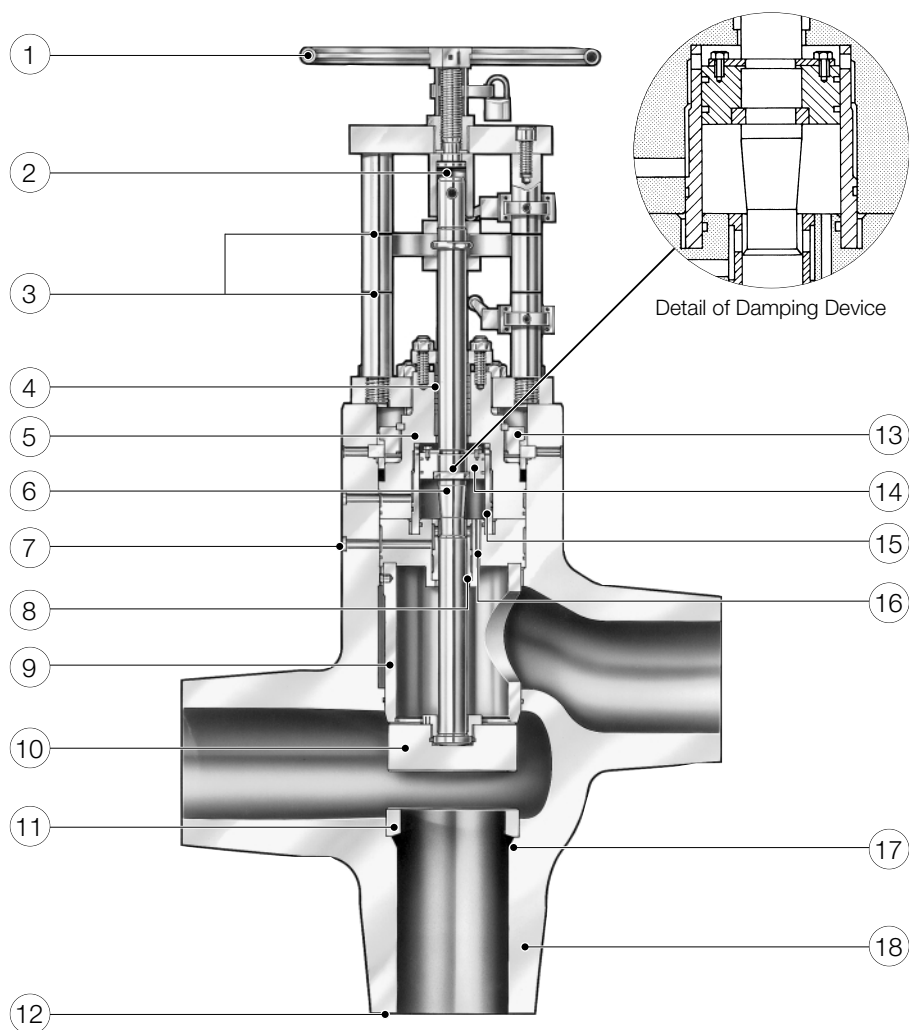

## Legenda

- 1 Fabricated steel handwheel.
- 2 Split stem (with separate coupling) to allow hand operation for commissioning and maintenance without having any effect on normal operation.
- 3 Position indication.
- 4 Expanded graphite packing.
- 5 Forged steel bonnet (A.S.T.M. A105-Carbon limit 0.25%).
- 6 Dewrance, Patented profiled stem arrangement to damp movement and prevent disc slamming onto seat when quick closing.
- 7 Exhaust from cylinder to quick acting valve.
- 8 Neck bush for adequate stem support.
- 9 Upper valve seat\*, hard faced (Stellite or equivalent) removable for maintenance.
- 10 Valve disc. self aligning, double seated\* and hard faced (Stellite or equivalent).
- 11 Lower valve seat, hard faced (Stellite or equivalent).
- 12 Butt weld ends.
- 13 Pressure seal bonnet.
- 14 Piston fitted with Piston rings.
- 15 Stainless steel cylinder liner.
- 16 Orifice to control flow into bottom of cylinder.
- 17 Lower seat ring welded.
- 18 Cast steel body (WCB) standard forged/fabricated body available in same sizes as an option.

\*Applies to two way changeover valve only.

## Operation

This system is designed to be "FAIL SAFE". Failure of the controlling electric or pneumatic supplies will cause the main changeover and outlet valves to close and so isolate the feed side of the feed heater or heater bank.

Float switches on feed water heaters are intended to have contacts normally made and to break with rising water level. Relays and solenoid are normally energised and are to be continuously rated.

Assuming the unit to be in normal operation the changeover valve will be in the position shown i.e. with the bypass line isolated. The out of balance forces acting on the disc caused by a combination of the differential area between the bottom and top of the disc and the pressure drop across the heater bank, will hold it in this position.

The solenoids on the Quick Acting Valve will be normally energised allowing air pressure on the top of the diaphragm to keep the valve closed.

Rising water level in a heater will cause the float switch contacts to break, de-energising the solenoids on the Quick Acting Valve causing it to open.

When the Quick Acting Valve opens, water is exhausted from the lower chamber (A) of the operating cylinder of both the Changeover valve and the 2-way outlet valve at a far greater rate than it can enter through the small filling orifice (Refer to (16) on previous page).

Feed Water passes through the adjustable orifice into chamber (B) and the resulting pressure difference on the pistons causes both valves to isolate the heater or heater bank.

Control of the speed of operation, to reduce the effects of hydraulic shock, is by means of the adjustable orifice over the major part of the stroke and finally by the patented specially profiled stem and port arrangement which prevents any tendency for the disc to slam onto the seat.

During the above closing process, the electrically operated Dump Valve has also opened allowing the safety relief valve to operate and reduce the pressure in the heater and feed piping to ensure that both valves are held firmly closed under all conditions.

Any increase in pressure from whatever source in the isolated section of feed water piping between the two main valves, will be automatically reduced by the safety relief valve.

At the point of main valve closure the Quick Acting Valves will also close to prevent unnecessary loss of feed water to drain.

Dewrance medium operated valves are available in a wide variety of sizes and pressure classes and can be supplied together with the ancillary equipment to suit individual customers requirements.

## Typical Feed Water Heater Isolation System

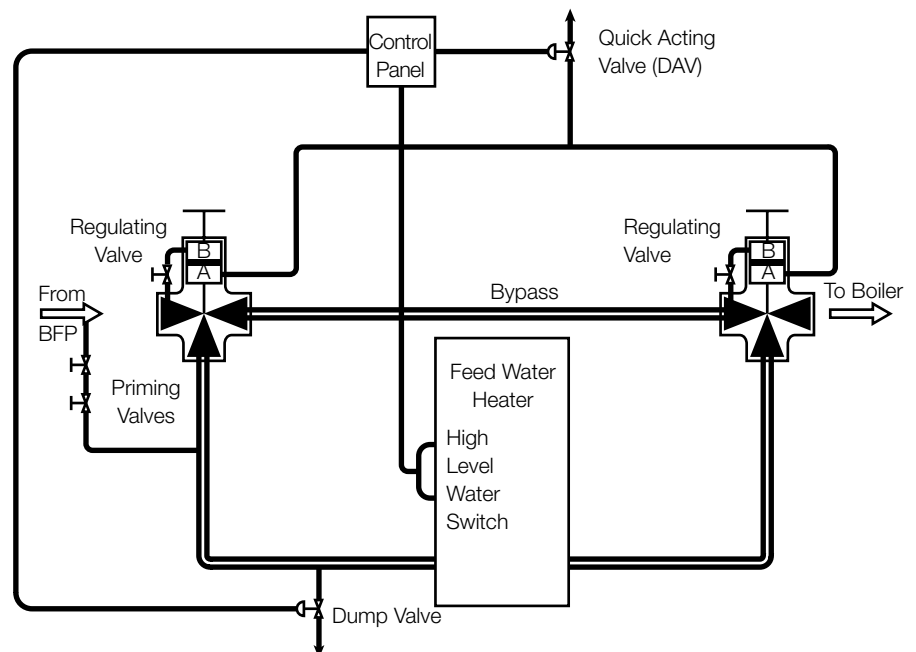

# Feed Water Heater - Isolation System

## Typical System

### Single Bank Isolation

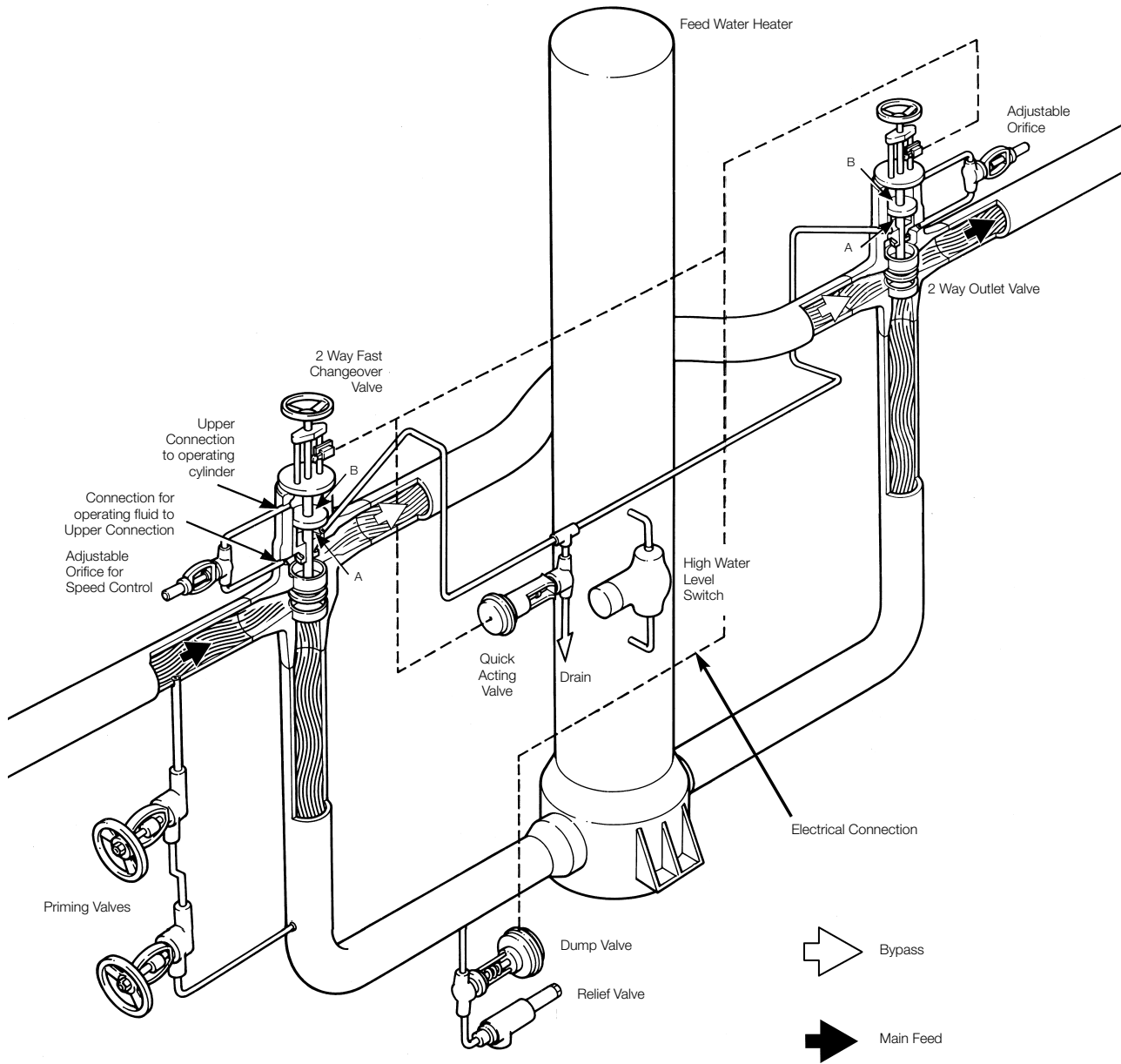

### Imperial 1715 int. Class (ASME B16.34 1996)

Prod. No.	ASTM Body Mat.		ASME code	-20° to 100°	Pressure in lbf/sq. in. at Temp. °F (for intermediate ratings use linear interpolation)																	
	Forged	Cast			B16.34	100°	200	300	400	500	600	650	700	750	800	850*	900	950	975	1000	1025	1050
W8A	D A105	E A216	Std.	4235	3859	3751	3624	3424	3127	3070	3047	2881	2355	1531	-	-	-	-	-	-	-	-
Y8A	D A105	E WCB	Spec.	4288	4288	4288	4288	4288	4076	3996	3967	3602	2939	1910	-	-	-	-	-	-	-	-

### Metric 1715 int. Class (ASME B16.34 1996)

Prod. No.	ASTM Body Mat.		ASME code	-30° to 38°	Pressure in Bar at Temp. °C (for intermediate ratings use linear interpolation)																	
	Forged	Cast			B16.34	38°	50	100	150	200	250	300	350	375	400	425	450*	475	500	525	550	575
W8A	D A105	E A216	Std.	291.9	286.3	265.2	258.4	250.5	238.6	221.3	211.3	208.5	197.2	164.5	114.7	-	-	-	-	-	-	-
Y8A	D A105	E WCB	Spec.	295.6	295.6	295.6	295.6	295.6	295.6	285.1	275.0	270.0	246.5	205.4	143.0	-	-	-	-	-	-	-

### Imperial 1690 int. Class (ASME B16.34 1996)

Prod. No.	ASTM Body Mat.		ASME code	-20° to 100°	Pressure in lbf/sq. in. at Temp. °F (for intermediate ratings use linear interpolation)																	
	Forged	Cast			B16.34	100°	200	300	400	500	600	650	700	750	800	850*	900	950	975	1000	1025	1050
A73	D A105	E A216	Std.	4173	3803	3696	3571	3374	3082	3025	3002	2839	2320	1509	-	-	-	-	-	-	-	-
A73	D A105	E WCB	Spec.	4225	4225	4225	4225	4225	4016	3938	3909	3549	2896	1882	-	-	-	-	-	-	-	-

### Metric 1690 int. Class (ASME B16.34 1996)

Prod. No.	ASTM Body Mat.		ASME code	-30° to 38°	Pressure in Bar at Temp. °C (for intermediate ratings use linear interpolation)																	
	Forged	Cast			B16.34	38°	50	100	150	200	250	300	350	375	400	425	450*	475	500	525	550	575
A73	D A105	E A216	Std.	287.6	282.1	261.3	254.7	246.9	235.1	218.1	208.2	205.4	194.3	162.1	113.0	-	-	-	-	-	-	-
A73	D A105	E WCB	Spec.	291.3	291.3	291.3	291.3	291.3	291.3	280.9	271.0	266.0	247.9	202.4	140.9	-	-	-	-	-	-	-

### Notes

\* Permissible but not recommended for prolonged usage above 800°F (425°C).  
Other pressure classes (up to 2500 class) available on request.

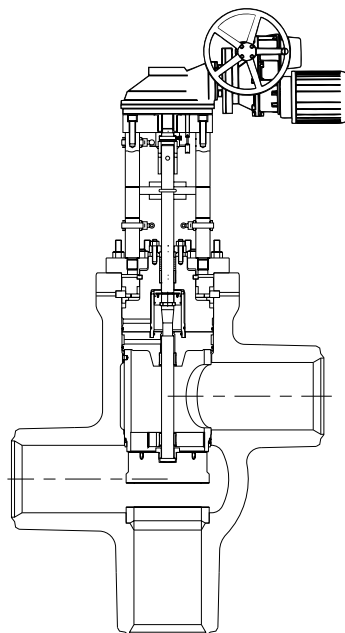

These valves can also be supplied with a direct mounted electric actuator.

# Feed Water Heater - Isolation System

Outlet, Angle Pattern, Medium Operated Valve

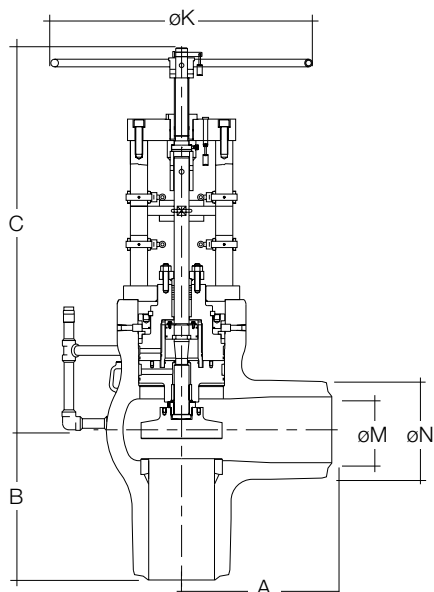

## Sizes 6"-20" ASME B16.34 1715 Int. Class

### Main component materials

Description	Carbon Steel
Body	ASTM A216 WCB (0.25% C max)
Pressure Seal	Expanded Graphite
Bonnet	ASTM A105
Valve Head	ASTM A105 H/F Stellite or Equivalent
Seat	ASTM A105 H/F Stellite or Equivalent

### Hydrostatic shell & seat leak test pressures

Press. Class	Body Material	
	ASTM	
	A-216 WCB	
	Shell	Seat
1715	6450 psi	4725 psi
1715	444 bar	326 bar

### Dimensions

Size	A	B	C	K	M	N	Product Numbers
6 in	12.40	12.40	33	18	5.12	6.81	
150 mm	315	315	838	457	130	173	W8AE150P
8 in	12.80	12.80	42	18	6.69	8.78	
200 mm	325	325	1067	457	170	223	W8AE200P
10 in	17	17	46	24	8.35	10.94	
250 mm	432	432	1169	610	212	278	W8AE250P
12 in	20.67	20.67	51	36	9.06	12.95	
300 mm	525	525	1295	914	230	329	W8AE300P
14 in	21.65	21.65	55	36	11.02	14.25	
350 mm	550	550	1397	914	280	362	W8AE350P
16 in	24.76	24.76	57	36	12.64	16.26	
400 mm	629	629	1448	914	321	413	W8AE400P
18 in	27.63	27.63	60	36	14.09	18.31	
450 mm	702	702	1524	914	358	465	W8AE450P
20 in	28.98	28.98	63	36	15.63	20.31	
500 mm	736	736	1600	914	397	516	W8AE500P

# Feed Water Heater - Isolation System

## Two Way Outlet, Tee Pattern, Medium Operated Valve

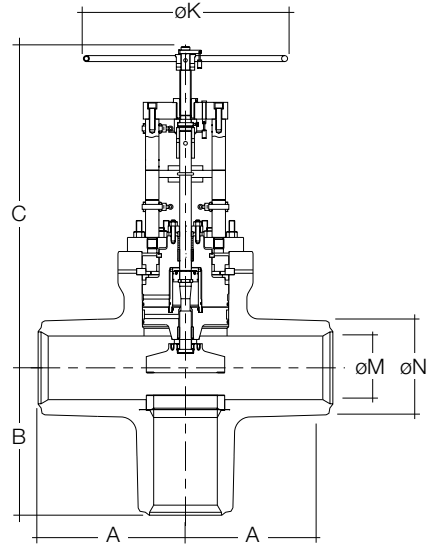

### Sizes 6"–20" ASME B16.34 1715 Int. Class

#### Main component materials

Description	Carbon Steel
Body	ASTM A216 WCB (0.25% C max)
Pressure Seal	Expanded Graphite
Bonnet	ASTM A105
Valve Head	ASTM A105 H/F Stellite or Equivalent
Seat	ASTM A105 H/F Stellite or Equivalent

#### Hydrostatic shell & seat leak test pressures

Press. Class	Body Material	
	ASTM	
	A-216 WCB	
	Shell	Seat
1715	6450 psi	4725 psi
1715	444 bar	326 bar

#### Dimensions

Size	A	B	C	K	M	N	Product Numbers
6 in	12.40	12.40	33	18	5.12	6.81	W8AE150P
150 mm	315	315	838	457	130	173	
8 in	12.80	12.80	42	18	6.69	8.78	W8AE200P
200 mm	325	325	1067	457	170	223	
10 in	17	17	47	18	8.35	10.94	W8AE250P
250 mm	432	432	1194	457	212	278	
12 in	20.67	20.67	51	36	10.04	12.99	W8AE300P
300 mm	525	525	1295	914	255	330	
14 in	21.65	21.65	55	36	11.02	14.25	W8AE350P
350 mm	550	550	1397	914	280	362	
16 in	24.76	24.76	57	36	12.64	16.26	W8AE400P
400 mm	629	629	1448	914	321	413	
18 in	27.64	27.64	60	36	14.09	18.31	W8AE450P
450 mm	702	702	1524	914	358	465	
20 in	28.98	28.98	63	36	15.63	20.31	W8AE500P
500 mm	736	736	1600	914	397	516	

# Feed Water Heater - Isolation System

## Two Way Intlet, Medium Operated Change Over Valve

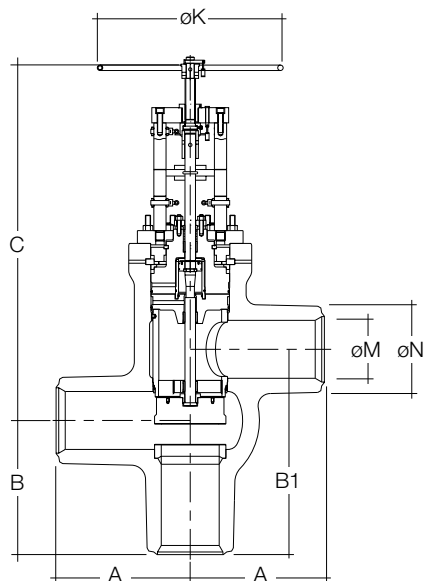

### Sizes 6"-20" ASME B16.34 1715 Int. Class

#### Main component materials

Description	Carbon Steel
Body	ASTM A216 WCB (0.25% C max)
Pressure Seal	Expanded Graphite
Bonnet	ASTM A105
Valve Head	ASTM A105 H/F Stellite or Equivalent
Seat	ASTM A105 H/F Stellite or Equivalent

#### Hydrostatic shell & seat leak test pressures

Press. Class	Body Material	
	ASTM A-216 WCB Shell	Seat
1715	6450 psi	4725 psi
1715	444 bar	326 bar

#### Dimensions

Size	A	B	B1	C	K	M	N	Product Numbers
6 in	12.40	12.40	18.70	39.25	18	5.12	6.81	Y8AE150P
150 mm	315	315	475	997	457	130	173	
8 in	12.80	12.80	19.10	51	24	6.69	8.78	Y8AE200P
200 mm	325	325	485	1295	610	170	223	
10 in	17	17	26.42	55.43	24	8.35	10.94	Y8AE250
250 mm	432	432	871	1408	610	212	278	
12 in	20.67	20.67	27.56	61.85	24	9.06	12.95	Y8AE300P
300 mm	525	525	700	1571	610	230	329	
14 in	21.65	21.65	28.54	65	36	11.02	14.25	Y8AE350P
350 mm	550	550	725	1651	914	280	362	
16 in	24.76	24.76	31.65	70	36	12.64	16.26	Y8AE400P
400 mm	629	629	804	1778	914	321	413	
18 in	27.63	27.63	44.13	75	36	14.09	18.31	Y8AE450P
450 mm	702	702	1121	1905	914	358	465	
20 in	28.98	28.98	46.22	79	36	15.63	20.31	Y8AE500P
500 mm	736	736	1174	2007	914	397	516	



# Feed Water Heater - Isolation System

## Spring Loaded Bypass Valve

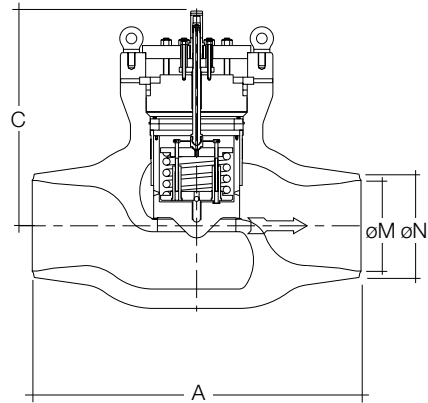

### Sizes 8"–18" ASME B16.34 1690 Int. Class

#### Main component materials

Description	Carbon Steel
Body	ASTM A216 WCB (0.25% C max)
Pressure Seal	Expanded Graphite
Bonnet	ASTM A105
Spring	FV 520B (17/4 PH)
Disc Guide	17/4 PHSS

#### Hydrostatic shell & seat leak test pressures

Press. Class	Body Material	
	ASTM	
	A-216 WCB	
	Shell	Seat
1690	6350 psi	450 psi
1690	438 bar	31 bar

#### Dimensions

Size	Lift press. psi/bar		A	C	M	N	Product Numbers
	Min.	Max.					
8 in	20	44	35	23.6	6.69	8.78	A73E200P
200 mm	1.4	3.0	889	399.4	169.9	223	
10 in	20	44	39	26.2	8.35	10.94	A73E250P
250 mm	1.4	3.0	991	665.5	212.1	277.9	
12 in	20	44	44.5	32.1	10.04	12.99	A73E300P
300 mm	1.4	3.0	1130	815.3	255	32.9	
14 in	20	44	49.5	37	11.02	14.25	A73E350P
350 mm	1.4	3.0	1257	939.8	279.9	362	
16 in	20	44	53	39.1	12.64	16.26	A73E400P
400 mm	1.4	3.0	1346	993.1	321	413	
18 in	20	44	61	41.3	14.09	18.31	A73E450P
450 mm	1.4	3.0	1549	1049	357.9	465.1	

# Feed Water Heater - Isolation System

## Materials of Construction

### ASTM specification Ferrous

Type	Forgings						Castings				Studs		
Main use	Bonnets, Covers, Seats Discs						Valve Bodies				Covers, Glands		
ASTM Spec (UNS)	A105	A182 F22	A276 420	A182 F347	BS970 316S31	A182 F91	A216 WCB	A217 WC6	A217 WC9	ASTM A743 GR.C12A	A193 GR.B7	A193 GR.B16	A193 GR.B6
Carbon %	0.75 max	0.15 max	0.15 min	0.08 max	0.07	0.08/0.12	0.30 max	0.20 max	0.05/0.18	0.12	0.37/0.49	0.36/0.47	0.15 max
Silicon %	1.5 max	0.5 max	1.0 max	1.0 max	1.0	0.2/0.5	0.6 max	0.6 max	0.6 max	0.2/0.5	0.15/0.35	0.15/0.35	1.0 max
Mang.%	-	0.3/0.6	1.0 max	2.0 max	2.0	0.3/0.6	1.0 max	0.5/0.8	0.40/0.70	0.3/0.6	0.65/1.1	0.45/0.70	1.0 max
Chrom.%	-	2.0/2.5	12.0/14.0	17.0/20.0	16.5/18.5	8.0/9.5	*0.5 max	1.0/1.5	2.0/2.75	8.0/9.5	0.75/1.2	0.80/1.15	11.5/13.5
Molybd.%	-	0.87/1.13	-	-	2.0/2.5	0.85/1.05	*0.20max	0.45/0.65	0.90/1.2	0.85/1.05	0.15/0.25	0.50/0.65	-
Nickel %	-	-	-	9.0/13.0	10.5/13.5	0.4 max	*0.5 max	*0.5 max	*0.50 max	0.4	-	-	-
Copper	-	-	-	-	-	-	*0.3 max	0.5 max	*0.50 max	-	-	-	-
Sulphur	0.08 max	0.04 max	0.03 max	0.03 max	0.03	0.01 max	0.045 max	0.045 max	0.045 max	0.018	0.04 max	0.040 max	0.03 max
Phosp. %	0.08 max	0.04 max	0.04 max	0.045max	0.045	0.02max	0.04 max	0.04 max	0.04 max	0.02	0.035 max	0.035 max	0.04 max
Niobium %	-	-	-	-	-	-	-	-	-	-	-	-	-
Vanadium	75/85	-	-	-	-	-	0.03	-	-	-	-	0.25/0.35	-
Almumin.%	2.0 max	-	-	-	-	-	-	-	-	-	-	0.015 max	-
Iron %	BAL	BAL	BAL	BAL	BAL	BAL	BAL	BAL	BAL	BAL	BAL	BAL	BAL
U.T.S.ksi min	70	60		75	74	85	70	70	70	85	125	125	110
Yield ksi min	36	30		30	30	60	36	40	40	60	105	105	85

\* Residual elements total 1.0% max

### Ferrous

Type	Plate	Bar				Nuts		
Main use	Covers	Stems		Pillars		Covers, Glands		
ASTM Spes (UNS)	ASTM A516 GR 70	A276 S43100	ASTM A565-XM32	A108 G10200	A193 GR.B7	A194 GR.2H	A194 GR.4	A194 GR.B8
Carbon %	0.18/0.31	0.2 max	0.08/0.15	0.18/0.23	0.37/0.49	0.40min	0.4/0.5	-0.08 max
Silicon %	0.13/0.45	1.0 max	0.35 max	-	0.15/0.35	0.4 max	0.15/0.35	1.0 max
Mang.%	0.6/1.2	1.0 max	0.5/0.9	0.3/0.6	0.65/1.1	1.0 max	0.7/0.9	2.0 max
Chrom.%	-	15/17	11/12.5	-	0.75/1.20	-	-	18.0/20.0
Molybd. %	-	-	1.5/2.0	-	0.15/0.25	-	0.20/0.30	-
Nickel %	-	1.25/2.50	2.0/3.0	-	-	-	-	8.0/10.5
Copper	-	-	-	-	-	-	-	-
Sulphur	0.035 max	0.03 max	0.025 max	0.05 max	0.04 max	0.05 max	0.04 max	0.03 max
Phosp. %	0.035 max	0.04 max	0.025 max	0.04 max	0.35 max	0.04 max	0.035 max	0.045 max
Niobium %	-	-	-	-	-	-	-	-
Vanadium	-	-	0.25/0.40	-	-	-	-	-
Almumin.%	-	-	-	-	-	-	-	-
Iron %	BAL	BAL	BAL	BAL	BAL	BAL	BAL	BAL
U.T.S.ksi min	55		115		100			
Yield ksi min	30		75		75			

### Non Ferrous

Type	Non Ferrous
Main use	Sleeve Gland
ASTM Spec (UNS)	B150 C63000
Almumin.%	9.0-11.0
Silicon %	0.25 max
Mang.%	1.5 max
Tin. %	0.2 max
Zinc %	0.3 max
Nickel %	4.0-5.5
Copper	BAL
Iron %	2.0-4.0
Phosp.%	-
Niobium %	-
Vanadium	-
Lead %	-
U.T.S.ksi min	94
Yield KIS MIN	46

